

LOT3&6&7:



All dimensions to be checked on-site during construction, the final dimensions of designs may be different from the kitchen shop drawings.

Kitchen



SUPERSTAR KITCHEN

Showroom: 32 Neilpark Drive,
East Tāmaki, Auckland 2013

Phone: 02108390772
Web: superstarkitchen.co.nz

Project No:

Designer:

Customer Name:

Project Address: 73C-D & 75 Ash Street, Avondale

LOT3&6&7:



All dimensions to be checked on-site during construction, the final dimensions of designs may be different from the kitchen shop drawings.

Kitchen



SUPERSTAR KITCHEN

Showroom: 32 Neilpark Drive,
East Tāmaki, Auckland 2013

Phone: 02108390772
Web: superstarkitchen.co.nz

Project No:

Designer:

Customer Name:

Project Address: 73C-D & 75 Ash Street, Avondale

LOT3&6&7:



All dimensions to be checked on-site during construction, the final dimensions of designs may be different from the kitchen shop drawings.

Kitchen

	Showroom: 32 Neilpark Drive, East Tāmaki, Auckland 2013	Project No:	Customer Name:
	Phone: 02108390772 Web: superstarkitchen.co.nz	Designer:	Project Address: 73C-D & 75 Ash Street, Avondale

LOT3&6&7:



All dimensions to be checked on-site during construction, the final dimensions of designs may be different from the kitchen shop drawings.

Kitchen



SUPERSTAR KITCHEN

Showroom: 32 Neilpark Drive,
East Tāmaki, Auckland 2013

Phone: 02108390772
Web: superstarkitchen.co.nz

Project No:

Designer:

Customer Name:

Project Address: 73C-D & 75 Ash Street, Avondale

LOT3&6&7:



All dimensions to be checked on-site during construction, the final dimensions of designs may be different from the kitchen shop drawings.

Kitchen

 SUPERSTAR KITCHEN	Showroom: 32 Neilpark Drive, East Tāmaki, Auckland 2013	Project No:	Customer Name:
	Phone: 02108390772 Web: superstarkitchen.co.nz	Designer:	Project Address: 73C-D & 75 Ash Street, Avondale

LOT3&6&7:

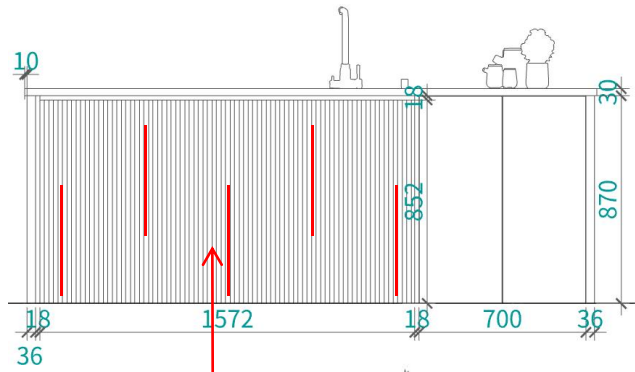

LED Lights

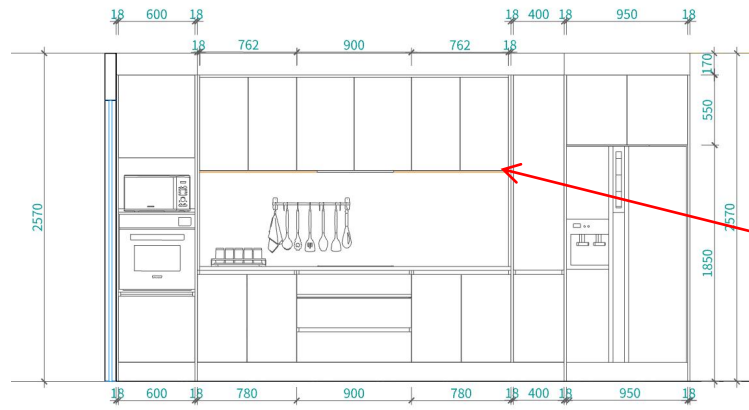

LED Lights

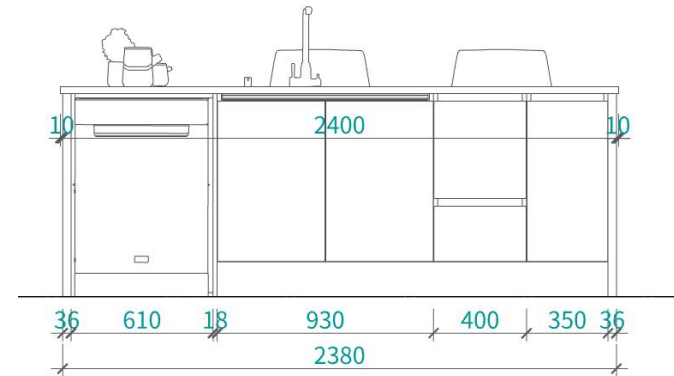
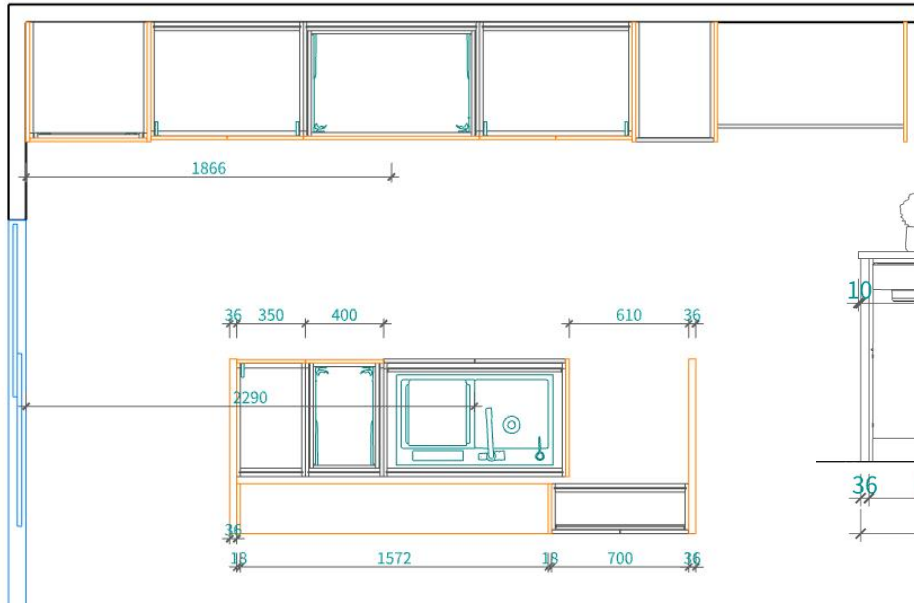

All dimensions to be checked on-site during construction, the final dimensions of designs may be different from the kitchen shop drawings.

Kitchen



SUPERSTAR KITCHEN

Showroom: 32 Neilpark Drive,
East Tāmaki, Auckland 2013

Phone: 02108390772
Web: superstarkitchen.co.nz

Project No:

Designer:

Customer Name:

Project Address: 73C-D & 75 Ash Street, Avondale

LOT3&6&7:



All dimensions to be checked on-site during construction, the final dimensions of designs may be different from the kitchen shop drawings.

Laundry



SUPERSTAR KITCHEN

Showroom: 32 Neilpark Drive,
East Tāmaki, Auckland 2013

Phone: 02108390772
Web: superstarkitchen.co.nz

Project No:

Designer:

Customer Name:

Project Address: 73C-D & 75 Ash Street, Avondale

LOT3&6&7:

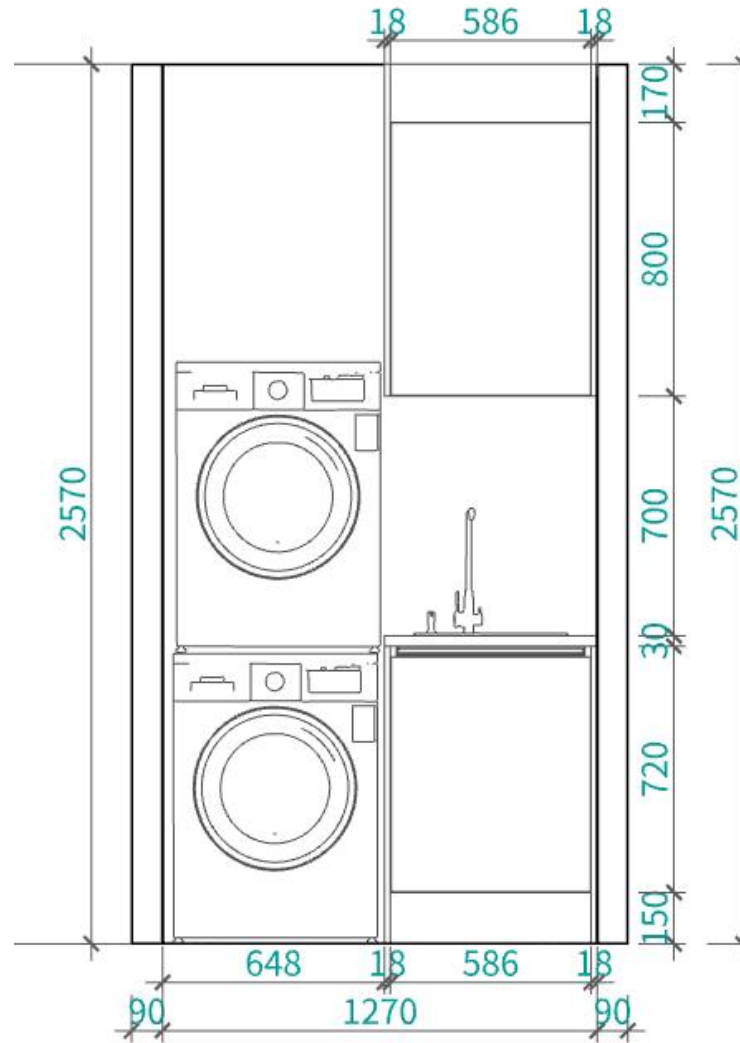

All dimensions to be checked on-site during construction, the final dimensions of designs may be different from the kitchen shop drawings.

Laundry



SUPERSTAR KITCHEN

Showroom: 32 Neilpark Drive,
East Tāmaki, Auckland 2013

Phone: 02108390772
Web: superstarkitchen.co.nz

Project No:

Designer:

Customer Name:

Project Address: 73C-D & 75 Ash Street, Avondale

LOT3&6&7:



All dimensions to be checked on-site during construction, the final dimensions of designs may be different from the kitchen shop drawings.

Wardrobe



SUPERSTAR KITCHEN

Showroom: 32 Neilpark Drive,
East Tāmaki, Auckland 2013

Phone: 02108390772
Web: superstarkitchen.co.nz

Project No:

Designer:

Customer Name:

Project Address: 73C-D & 75 Ash Street, Avondale

LOT3&6&7:



All dimensions to be checked on-site during construction, the final dimensions of designs may be different from the kitchen shop drawings.

Wardrobe



SUPERSTAR KITCHEN

Showroom: 32 Neilpark Drive,
East Tāmaki, Auckland 2013

Phone: 02108390772
Web: superstarkitchen.co.nz

Project No:

Designer:

Customer Name:

Project Address: 73C-D & 75 Ash Street, Avondale

LOT3&6&7:



All dimensions to be checked on-site during construction, the final dimensions of designs may be different from the kitchen shop drawings.

Wardrobe



SUPERSTAR KITCHEN

Showroom: 32 Neilpark Drive,
East Tāmaki, Auckland 2013

Phone: 02108390772
Web: superstarkitchen.co.nz

Project No:

Designer:

Customer Name:

Project Address: 73C-D & 75 Ash Street, Avondale

Terms and conditions

1.Quotation Validity: This quotation is valid for 2 months. After the expiry date, prices may change according to fluctuations in material costs.

2.Payment Terms: A 50% deposit is required upon order confirmation, 40% is due prior to benchtop delivery, The remaining 10% must be paid within 5 working days of job completion.

3.Scope of Work: Unless specifically stated in the quotation, the following are not included: plumbing, electrical works, external rangehood installation, flooring, tiling, painting, decorating, splashback or any other construction-related work. The removal of old tiles, kitchen equipment, or other obstructions in the work area is also excluded.

4.Appliance & Electrical Installation: Appliance installation and electrical works are not included in the quoted price.

5.Delivery Charges: Additional charges may apply for deliveries outside the Auckland area.

6.Construction Schedule Approval: Acceptance of this quotation is subject to our approval of the proposed construction schedule.

7.Warranty: We offer a 5-year warranty on cabinetry and engineered stone benchtops covering manufacturing and installation quality. Warranties for hardware and accessories are subject to the original supplier's warranty policy.

8Automatic Acceptance: If the customer proceeds with the project without signing the quotation agreement, it shall be deemed as automatic acceptance of all the above terms and conditions.

I _____ as representative of the Customer and as Guarantor have read and agreed to the Quotation and Terms of Trade that make up this Agreement. Date:

All dimensions to be checked on-site during construction, the final dimensions of designs may be different from the kitchen shop drawings.

	Showroom: 32 Neilpark Drive, East Tāmaki, Auckland 2013	Project No:	Customer Name:
	Phone: 02108390772 Web: superstarkitchen.co.nz	Designer:	Project Address: 73C-D & 75 Ash Street, Avondale